



# Alfa Laval AlfaNovaTW 66

## Fusion-bonded plate heat exchanger in 100% stainless steel

### Introduction

Alfa Laval AlfaNovaTW fusion-bonded plate heat exchangers are made of 100% stainless steel. They are optimized to give efficient thermal performance in tap water and water-to-water applications while ensuring minimized metal leaching by its inert properties.

AlfaNovaTW provides efficient heat transfer with a small footprint, and extreme pressure fatigue resistance.

### Applications

Suitable for a wide range of applications, such as:

- HVAC heating and cooling
- Domestic hot water production

### Benefits

- Compact
- Easy to install
- Self-cleaning
- Low level of service and maintenance is required
- All units are pressure and leak tested
- Gasket free
- Copper free

### Branded Features



**AlfaNova**

100% stainless steel



**ValuePlus**

Total support – with value-adding options to fit your needs

### Design

The AlfaFusion filler material seals and holds the plates together at the contact points ensuring optimal heat transfer efficiency and pressure resistance. Using advanced design technologies and extensive verification guarantees the highest performance and longest possible service life.

Based on standard components and a modular concept, each unit is custom-built to meet the specific requirements of each individual installation.



### Examples of connections

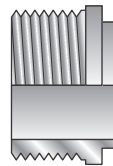

External thread

## Technical Data

### Standard materials

Cover plates	Stainless steel
Connections	Stainless steel
Plates	Stainless steel
AlfaFusion filler	Stainless steel

### Dimensions and weight <sup>1</sup>

A measure (mm)	12.3 + (2.18 * n)
A measure (inches)	0.48 + (0.09 * n)
Weight (kg) <sup>2</sup>	2.94 + (0.22 * n)
Weight (lb) <sup>2</sup>	6.48 + (0.49 * n)

<sup>1</sup> n = number of plates

<sup>2</sup> Excluding connections

### Standard data

Volume per channel, litres (gal)	0.147 (0.0388)
Max. particle size, mm (inch)	1 (0.039)
Max. flowrate <sup>1</sup> m <sup>3</sup> /h (gpm)	14 (61.6)
Flow directions	Parallel
Min. number of plates	10
Max. number of plates	150

<sup>1</sup> Water at 5 m/s (16.4 ft/s) (connection velocity)

## Dimensional Drawing

Measurements in mm (inches)

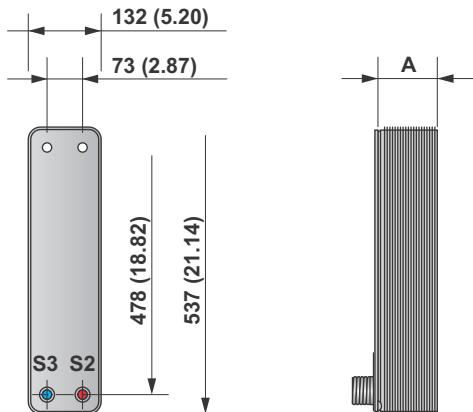

## Design pressure and temperature

### AlfaNovaTW 66- PED approved pressure/temperature graph

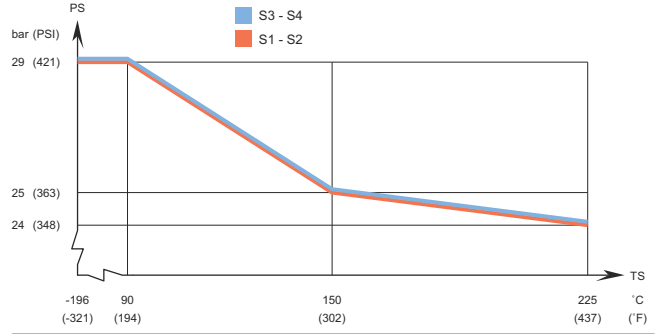

Designed for full vacuum.

Alfa Laval plate heat exchangers are available with a wide range of pressure vessel approvals. Please contact your Alfa Laval representative for more information.

**NOTE:** Values above are to be used as an indication. For exact values, please use the drawing generated by the Alfa Laval configurator or contact your local Alfa Laval representative.

This document and its contents are subject to copyrights and other intellectual property rights owned by Alfa Laval Corporate AB. No part of this document may be copied, re-produced or transmitted in any form or by any means, or for any purpose, without Alfa Laval Corporate AB's prior express written permission. Information and services provided in this document are made as a benefit and service to the user, and no representations or warranties are made about the accuracy or suitability of this information and these services for any purpose. All rights are reserved.

200002615-2-EN-GB

© Alfa Laval Corporate AB