

# Alfa Laval ThinkTop® D30

## Sensing and control

### Introduction

The Alfa Laval ThinkTop® D30 is a basic, easy-to-install valve control unit for fluid handling in hygienic applications. A compact, cost-effective alternative to external solenoid valves, it is ideal for use where space is limited, and operational simplicity and reliability is important. ThinkTop D30 simplified solution for Alfa Laval hygienic valves.

### Application

The Alfa Laval ThinkTop D30 is designed for use in hygienic applications across the dairy, food, beverage, biotechnology, pharmaceutical and many other industries.

### Benefits

- No-hassle intuitive control unit
- Easy-to-install, plug-and-play
- 360° LED indication and compact design to fit wherever space is limited
- Cost-effective alternative to using external solenoid valves
- Reliable, optimized hygienic design and easy to operate

### Standard design

The ThinkTop D30 valve control unit consists of a proven, air pressure sensor system with 360-degree LED visual status indicator, an integrated 3/2-way solenoid valve for a spring-loaded actuator, and a valve control board for connection to all major programmable logic controller (PLC) systems with a digital PNP interface. It fits on most Alfa Laval hygienic valves; no adapter is required. For more details check table with compatible valves.

Installation onto the top of the valve is straightforward. No special expertise or tools are required. No manual push-button setup. Simply plug and play the ThinkTop D30.

### Working principle

The Alfa Laval ThinkTop D30 valve control unit is fitted with one solenoid valve that can convert compressed air and the electrical PLC signal into mechanical energy to activate or deactivate the spring-loaded pneumatic valve actuator. The air pressure sensor system sends signals to the PLC system to activate or deactivate the pneumatic valve actuator.

Each control unit and its air pressure sensor fit most Alfa Laval hygienic valve. This eliminates the need to re-adjust the sensors and boosts productivity.



360° LEDs conveniently display the main valve position, solenoid activation and local fault indication on the control unit.

### Certificates



## TECHNICAL DATA

### Communication

Interface:	Digital PNP
------------	-------------

### Sensor board

Max current consumption:	45mA
Feedback signal #1:	De-energized valve
Feedback signal #2:	Energized valve
Feedback signal #3:	Alarm

### Solenoid valve

Max current consumption:	45mA
Air supply:	400 - 700 kPa (4 - 7 bar)
Type of solenoid:	3/2-ways
Number of solenoids:	1
Manual hold override:	Yes
Push-in fittings:	ø6 mm

## PHYSICAL DATA

### Materials

Steel parts:	Stainless Steel and Brass
Plastic parts:	Black Nylon PA 6
Seals:	Nitrile (NBR) rubber

### Environment

Working temperature:	-10 °C to +50 °C
Protection class:	P66 and IP67

### Cable connection

Max wire size:	0.5 mm <sup>2</sup> (AWG 20)
----------------	------------------------------



### Note!

For further information: See also ESE02248

## Options

- Pneumatic tubing interface

## Accessories

- Various cable options
- Elbow pneumatic fittings for adapting various tubing
- Threaded plate for indication pin on SRC, SMP-BC and i-SSV valves
- Adaptor for Unique SSSV valves

## Compatible valves

ARC	Yes	SBV	Yes
SRC	Yes	Koltek	Yes
Unique SSV	Yes	SMP valves	Yes
i-SSV	Yes	DV-ST ≤ DN50	Yes
LKLA-T	Yes	Unique Mixproof	No
LKLA	No	Unique SSV Long Stroke	No
Air/Air actuator	No	Unique SSV High pressure DN80 - DN100	No
		SRC Long stroke	No
		Unique SSV DN125 - DN150	No

## Electrical connection

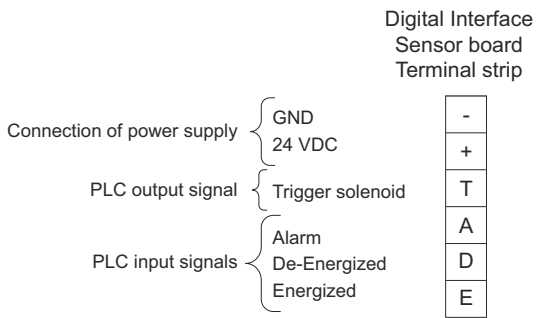

## Dimensions (mm)

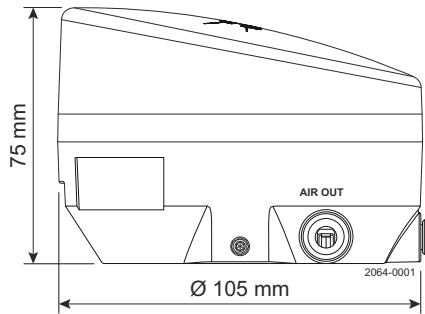

This document and its contents are subject to copyrights and other intellectual property rights owned by Alfa Laval Corporate AB. No part of this document may be copied, re-produced or transmitted in any form or by any means, or for any purpose, without Alfa Laval Corporate AB's prior express written permission. Information and services provided in this document are made as a benefit and service to the user, and no representations or warranties are made about the accuracy or suitability of this information and these services for any purpose. All rights are reserved.